

TORSPEC™ VARIABLE SPEED DRIVE

INSTALLATION AND MAINTENANCE INSTRUCTIONS

TORSPEC MODEL 100TCD-M

TORSPEC VARIABLE SPEED DRIVES

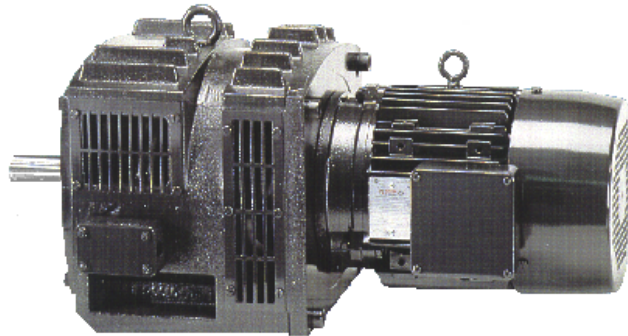

SIMPLE - RUGGED - RELIABLE

WARNING

Disconnect all incoming power before working on this equipment.

Follow power lockout procedures.

Use extreme caution around electrical equipment.

Do not touch the circuit board while power is applied.

TORSPEC™

International Inc.
40 Claireville Drive, Etobicoke
(Toronto), Ontario, Canada M9W 5T9
Phone: (416) 213-1026
Fax: (416) 213-0821
E-mail: sales@torspec.com

International (USA) Inc.
13507-C East Boundary Road
Midlothian (Richmond), VA U.S.A. 23112
Phone: (804) 744-5521
Fax: (804) 744-9131
E-mail: Torspecusa@aol.com

Web-Site: www.torspec.com

Manufacturers & Suppliers of World Class Quality Variable Speed Drives & Controls

TORSPEC MODEL 100TCD-M DISMANTLING INSTRUCTIONS

CAUTION - BE SURE TO DISCONNECT POWER AND FOLLOW LOCK-OUT PROCEDURES AS SPECIFIED BY LAW **BEFORE** OPENING ANY TERMINAL BOXES OR TOUCHING ANY WIRING.

D1: Open terminal box and disconnect drive wires. **EXTREME CAUTION** should be exercised with the small wires going to the tach generator, as they can be easily broken.

Hint: (Look for broken wires, or poor connections.)

D2: Remove four bolts holding output assembly to main casing. Remove output assembly while feeding wires through the hole, once the wires are free, the output assembly can be completely removed.

Hint: (Look for physical damage, remove any build up of foreign material on polewheel which could cause binding. Binding will cause the drive to run at full speed when the motor is started even if the clutch is turned off.)

D3: The polewheel is removed by removing the bolt in the center that is attaching it to the output shaft and inserting a larger 10mm bolt to push it off.

D4: The coil is held in place by a circlip at the back and silicone sealant at the front. After removing the circlip it is necessary to use a thin blade to break the sealant between the coil form and the front of the output assembly. **Care must be used, the former is breakable.**

Hint: (Look for physical damage, signs of overheating, coil should be 20 to 40 ohms depending on size. Low resistance will cause the control fuses to blow, too high will result in poor performance.)

D5: To separate the coil and tach wires cut the waxed string and **carefully** slide the rubber tube off. If the tach is being replaced, a string or small wire tied to the old tach wires before removing can be used to assist in pulling in the new wires.

Hint: (Look for broken wires, tach should be 220 ohms, a bad tach will cause the drive to run at full speed when the controller is energized.)

D6: Remove the tach cover plate and tach stator. The tach armature is held in place by a friction fit star tolerance ring and can be pulled off. **Be sure not to damage the magnetic strip.**

Hint: (Look for broken magnetic strip, this will give the same symptoms as a bad tach.)

D7: Remove the shaft out of the assembly from the output shaft side by pressing on the polewheel side of the shaft.

D8: The rear bearing that is still in the housing can be removed after the retaining plate has been removed.

D9: Remove the motor adapter flange from the main casing. Remove the 4 cap head screws holding the torque tube assembly to the hub on the motor shaft. Two grub screws hold the hub on the shaft, be sure to remove these grub screws completely as one is counter sunk into the shaft.

Hint: (Look for pitting and/or lifting of the copper lining on the torque tube, this is what transmits the power and damage here will cause the drive to be short of power)

TORSPEC MODEL 100TCD-M ASSEMBLY INSTRUCTIONS

USE A THREAD LOCKING COMPOUND ON ALL BOLTS

- A1: If the motor is being replaced it will be necessary to dimple the shaft in the same location as the original motor. ***This location is critical for proper alignment.*** Use an anti-seize compound on the shaft. Mount the torque tube hub with one of the grub screws in the dimple
- A2: Mount the motor adapter flange onto the motor flange with the flat on the bottom. Mount the torque tube onto the hub. Bolt the motor assembly onto the main casing.
- A3: Mount the pre-greased rear bearing into the output assembly by pressing on the outer and inner race with a press, ***do not hammer.*** Install rear bearing retaining plate onto stator body. Press the front bearing and spacer on to the shaft with the press. Insert the shaft assembly into the output assembly from the front side by pressing on the inner and outer front bearings while supporting the rear bearing.
- A4: Mount the star tolerance ring and tach armature onto the shaft. Feed the tach wires through the hole in the output assembly and slide the tach stator plate over the shaft and bolt to the output assembly. ***Be sure not to pinch the tach wires.***
- A5: Apply silicone rubber to the front of the main coil and push the coil onto the output assembly. Install the coil circlip. Push the tach wires, then the coil wires into the rubber sleeving. Tie off with a piece of waxed string.
- A6: Bolt the polewheel onto the shaft ensuring the spring pins are in place and the polewheel completely seats.
- A7: Insert the output assembly into the casing while feeding the wires through the hole. Bolt into place on main casing.

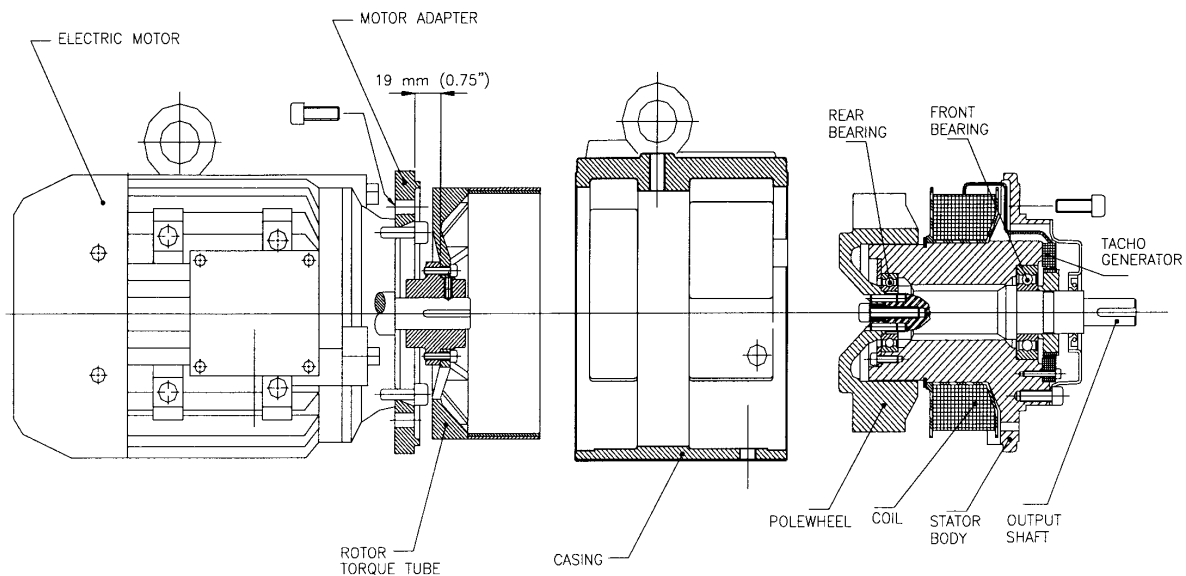

TORSPEC MODEL 100TCD-M PARTS LIST

PART NO.	DESCRIPTION
2008M	OUTPUT SHAFT SPACER
2307M	OUTPUT SHAFT D80 19MM CODE S1
2314M	OUTPUT FLANGE D80/D90 FIXED BY 4-M8X30 SOCKET HD. CAP CODE F1
2316M	MOTOR ADAPTER D80/D90 FIXED BY 4-M10X30 SOCKET HD. CAP CODE D1
2317M	MOTOR ADAPTER D100C FIXED NBY 4-M10X30 SOCKET HD. CAP CODE D1
2320M	METRIC MOTOR SEE MOTOR NAMEPLATE FOR DETAILS FIXED BY D80/90=4-M10X30 HEX HD. CAP II D100C=4-M8X30 HEX HD. CAP CODE D1
2322M	ROTOR HUB D80 19MM FIXED BY 1-M6X6 CUP POINT GRUB SCREW, 1-M6X6 CONE POINT GRUB SCREW CODE D1
2323M	ROTOR HUB D90 24MM FIXED BY 1-M6X6 CUP POINT GRUB SCREW, 1-M6X6 CONE POINT GRUB SCREW CODE D1
2324M	ROTOR HUB D100C 28MM FIXED BY 1-M6X6 CUP POINT GRUB SCREW, 1-M6X6 CONE POINT GRUB SCREW CODE D1
2325M	INPUT ASSY. METRIC CODE K1
2350M	KEYSTOCK METRIC D80 6MM SQ.X25MM CODE S1
2218S	OUTPUT FLANGE R60 SEW FIXED BY 4-M6X25 SOCKET HD. CAP CODE F4
2219S	OUTPUT SHAFT R60 SEW CODE S4
2220S	SHAFT SPACER FOR PART NO. 2219S R60 SEW CODE S4
2001	CASING
2002	STATOR BODY ASSY. FIXED BY 4-M8X10 SOCKET HD. CAP
2004	TACH COVER FIXED BY 4-M8X20 SOCKET HD. CAP
2016	GRILLES SMALL INLET FIXED BY 4-M5X8 PAN HD. SLOTTED
2017	GRILLES LARGE OUTLET FIXED BY 4-M5X8 PAN HD SLOTTED
2022	BEARING FRONT 6206Z
2023	BEARING REAR 6006Z
2024	BEARING REAR RETAINER PLATE FIXED BY 4-M5X12 SOCKET HD. CAP
2028	OIL SEAL 30X52X7
2030	COIL RETAINING RING
2060	STD. COIL FOR 4/1.5KW, 2/3KW FIXED BY PART NO. 2030
2063	STD. COIL FOR 4/.75KW, 4/1.1KW, 2/1.1KW, 2/1.1KW, 2/1.5KW, 2/2.2KW FIXED BY PART NO 2030
2066	HP COIL FOR 4/1.5KW, 2/3KW FIXED BY PART NO. 2030 CODES H10, H20, N1, N2
2069	HP COIL FOR 4/.75KW, 4/1.1KW, 2/1.1KW, 2/1.5KW, 2/2.2KW FIXED BY PART NO 2030 CODES H10, H20, N1, N2
2073	TORQUE TUBE/ROTOR ASSY. 4 POLE FIXED BY 4-M5X20 SOCKET HD. CAP
2079	POLEWHEEL STD. FIXED BY 1-M8X30 SOCKET HD. CAP, 1-M8 FLAT WASHER, 2-M5X20 SLOTTED SPRING PINS
2087	POLEWHEEL REDUCED FIXED BY 1-M8X30 SOCKET HD. CAP, 1-M8 FLAT WASHER, 2-M5X20 SLOTTED SPRING PINS CODE R
2089	TORQUE TUBE /ROTOR ASSY. 2 POLE FIXED BY 4-M5X20 SOCKET HD. CAP
2173	TORQUE TUBE NICKEL PLATED /ROTOR ASSY. 4 POLE FIXED BY 4-M5X20 SOCKET HD. CAP SAME AS 2073
2189	TORQUE TUBE NICKEL PLATED /ROTOR ASSY. 2 POLE FIXED BY 4-M5X20 SOCKET HD. CAP SAME AS 2089
2302	TOTALLY ENCLOSED COVER LEFT HAND FIXED BY 4-M5X12 SOCKET HD. CAP CODES T1, T2
2303	TOTALLY ENCLOSED COVER RIGHT HAND FIXED BY 4-M5X12 SOCKET HD. CAP CODES T1, T2
2319	PLASTIC PLUGS 4- # 2 CODES T1, T2, H10, H20, N1, N2
2501	HOSEPROOF COVER LEFT HAND FIXED BY 4-M5X12 SOCKET HD. CAP CODES N1, N2
2503	HOSEPROOF COVER RIGHT HAND FIXED BY 4-M5X12 SOCKET HD. CAP CODES N1, N2
9005	TERMINAL BOX FIXED BY 4-M5X60 STUD, 4-M5 RUBBER WASHERS, 4-M5 FLAT WASHERS, 4-M5 LOCKNUT
9006	TERMINAL BOX LID X2
9008	TACH GENERATOR ASSY. FIXED BY 4-M4X16 SOCKET HD. CAP, 4-M4 FLAT WASHER
9014	TERMINAL BOX GASKET X3 FOR CODES H10, H20, N1, N2, T1, T2
9031	STAR TOLERANCE RING
9034	EYEBOLT M12
9035	PLASTIC PLUG 1- #12 CODES T1, T2
9038	OIL SEAL 30X47X7 CODES F1, F2
9039	NAMEPLATE FIXED BY 4-M6X3.5MM TAPPING SCREWS
9305	TERMINAL BLOCK 4 WAY FIXED BY 1-M5X16 SOCKET HD. CAP
9306	TERMINAL BLOCK 6 WAY FIXED BY 1-M5X16 SOCKET HD CAP CODES B? Y?
9500	TACH ARMATURE FIXED BY PART NO. 9031

TORSPEC MODEL 100TCD-M PARTS DIAGRAM

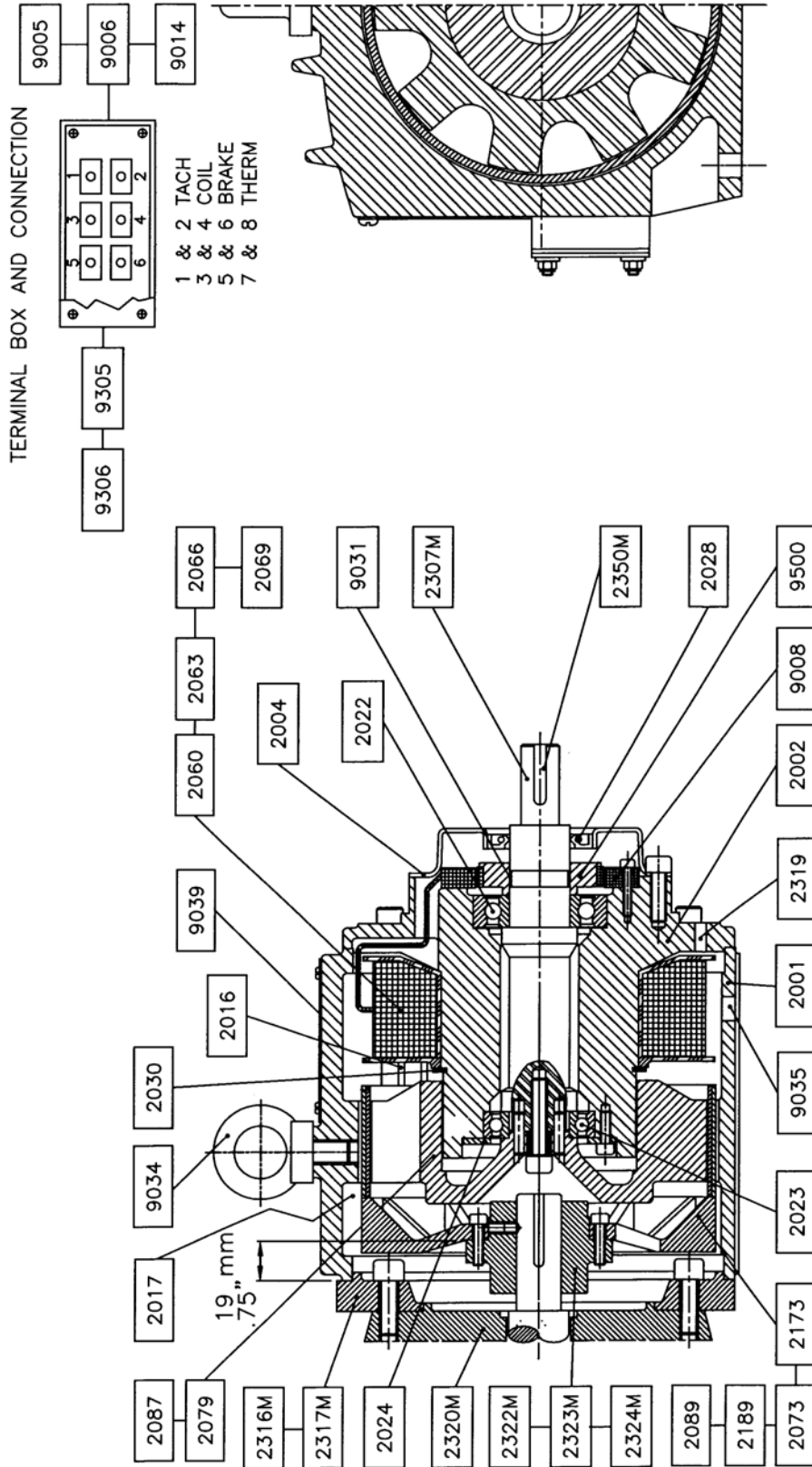

NOTES:

NOT SHOWN:

- 2219S SEW SHAFT
- 2218S R60 OUTPUT FLANGE
- 2220S SHAFT SPACER
- 9038 OIL SEAL
- 2302.03 TOTALLY ENCLOSED COVERS
- 2501, 03 HOSEPROOF COVER LEFT HAND, RIGHT HAND
- 2314M D80/90 OUTPUT FLANGE
- 2325M INPUT ASSEMBLY

TORSPEC INTERNATIONAL INC.		100TCD CLUTCH UNIT – METRIC BASIC UNIT – FOOT MOUNTED	
File: Instr_100/100assy_M	March: 2002	R#	1

DRIVE FEET MOUNTING PROCEDURES

F1: Push slotted Shims under the Coupling lowest mounting feet and moderately tighten the Bolts

F2: Align the unit. Insert Feeler Gauges under the remaining feet during the alignment process to level the unit.

F3: Replace feeler gauges with equal thickness of slotted Shims. Use a few thick shims rather than a large number of thin shims.

F4: Alternately tighten Bolts.

F5: Recheck alignment and change shims as required.

F6: Push slotted Shims under AC Motor mounting feet and moderately tighten the bolts.

Note:

-The decision to mount (bolt) the Motor feet should be based on the application dynamics. (I.e. vibration/support). It is not always necessary to mount the motor feet and is specifically motor size related.

-When Drives are purchased on base, base must also be leveled and secured.

Warning:

Failure to properly mount and level drive unit may result in distortion to the drive housing, torque tube, mechanical failure, misalignment, and premature bearing wear.