

TORSPEC™ VARIABLE SPEED DRIVE

INSTALLATION AND MAINTENANCE INSTRUCTIONS

TORSPEC MODEL 180TCD-M

TORSPEC VARIABLE SPEED DRIVES

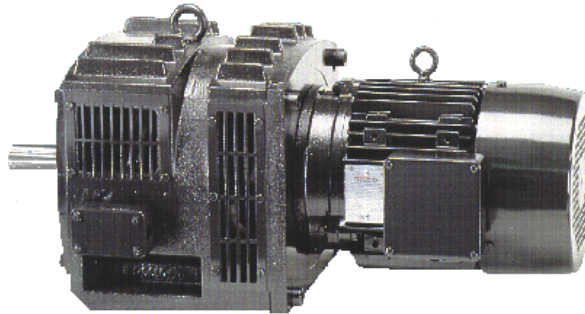

SIMPLE - RUGGED - RELIABLE

WARNING

Disconnect all incoming power before working on this equipment.

Follow power lockout procedures.

Use extreme caution around electrical equipment.

Do not touch the circuit board while power is applied.

TORSPEC™

Torspec International Inc.
40 Claireville Drive, Etobicoke
(Toronto), Ontario, Canada M9W 5T9
Phone: (416) 213-1026
Fax: (416) 213-0821
E-mail: sales@torspec.com

Torspec International (USA) Inc.
13507-C East Boundary Road
Midlothian (Richmond), VA U.S.A. 23112
Phone: (804) 744-5521
Fax: (804) 744-9131
E-mail: Torspecusa@aol.com

Web-Site: www.torspec.com

Manufacturers & Suppliers of World Class Quality Variable Speed Drives & Controls

TORSPEC MODEL 180TCD-M DISMANTLING INSTRUCTIONS

CAUTION - BE SURE TO DISCONNECT POWER AND FOLLOW LOCK-OUT PROCEDURES AS SPECIFIED BY LAW **BEFORE** OPENING ANY TERMINAL BOXES OR TOUCHING ANY WIRING.

D1: Open terminal box and disconnect drive wires. **EXTREME CAUTION** should be exercised with the small wires going to the tach generator, as they can be easily broken.

Hint: (Look for broken wires, or poor connections.)

D2: Remove four bolts holding output assembly to main casing. Remove output assembly while feeding wires through the hole, once the wires are free, the output assembly can be completely removed.

Hint: (Look for physical damage, remove any build up of foreign material on polewheel which could cause binding. Binding will cause the drive to run at full speed when the motor is started even if the clutch is turned off.)

D3: The polewheel is removed by removing the bolt in the center that is attaching it to the output shaft and inserting a larger 14mm bolt to push it off.

D4: The coil is held in place by a circlip at the back and silicone sealant at the front. After removing the circlip it is necessary to use a thin blade to break the sealant between the coil form and the front of the output assembly. **Care must be used, the former is breakable.**

Hint: (Look for physical damage, signs of overheating, coil should be 20 to 40 ohms depending on size. Low resistance will cause the control fuses to blow, too high will result in poor performance.)

D5: To separate the coil and tach wires, cut the waxed string and **carefully** slide the rubber tube off. If the tach is being replaced, a string or small wire tied to the old tach wires before removing can be used to assist in pulling in the new wires.

Hint: (Look for broken wires, tach should be 220 ohms, a bad tach will cause the drive to run at full speed when the controller is energized.)

D6: Remove the tach cover plate and tach stator. The tach armature is held in place by two grub screws and can be pulled off once loosened. **Be sure not to damage the magnetic strip.**

Hint: (Look for broken magnetic strip, this will give the same symptoms as a bad tach.)

D7: Remove the bearing retaining plate and remove the shaft out of the assembly from the polewheel side by pressing on the tach side of the shaft.

D8: The ball bearing and front roller bearing inner race can now, be pulled off.

D9: Remove the motor adapter flange from the main casing. Remove the 6 cap head screws holding the torque tube assembly to the hub on the motor shaft. Two grub screws hold the hub on the shaft, be sure to remove these grub screws completely as one is counter sunk into the shaft.

Hint: (Look for pitting and/or lifting of the copper lining on the torque tube, this is what transmits the power and damage here will cause the drive to be short of power)

TORSPEC MODEL 180TCD-M ASSEMBLY INSTRUCTIONS

USE A THREAD LOCKING COMPOUND ON ALL BOLTS

- A1: If the motor is being replaced it will be necessary to dimple the shaft in the same location as the original motor. **This location is critical for proper alignment.** Use an anti-seize compound on the shaft. Mount the torque tube hub with one of the grub screws in the dimple. Position the hub on such way that distance is 33mm between front fitting face of motor adapter flange and face on hub where rotor-fan fits. Refer to drawing below.
- A2: Mount the motor adapter flange onto the ac motor flange with the flat on the bottom. Mount the torque tube onto the hub. Bolt the motor assembly onto the main casing.
- A3: Mount the pre-greased outer roller bearing into the output assembly. Press the inner race onto the shaft. Press the pre-greased ball bearing onto the back of the shaft, be sure to press on the inner race only. Insert the shaft assembly into the output assembly from the polewheel side by pressing on the inner and outer rear bearing.
- A4: Mount the tach armature onto the shaft and tighten both grub screws. Feed the tach wires through the hole in the output assembly and slide the tach stator plate over the shaft and bolt to the output assembly. **Be sure not to pinch the tach wires.**
- A5: Apply silicone rubber to the front of the main coil and push the coil onto the output assembly. Install the coil circlip. Push the tach wires, then the coil wires into the rubber sleeving. Tie off with a piece of waxed string.
- A6: Bolt the polewheel onto the shaft ensuring the spring pins are in place and the polewheel completely seats.
- A7: Insert the output assembly into the casing while feeding the wires through the hole. Bolt into place on main casing.

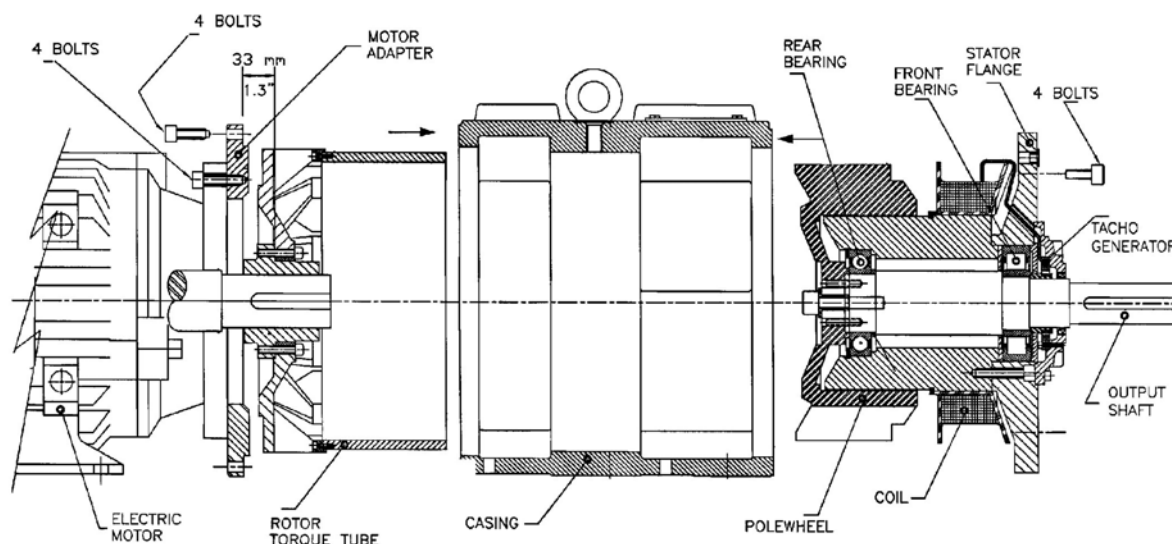

180TCD-M

TORSPEC MODEL 180TCD-M PARTS LIST

PART NO.	DESCRIPTION
5008M	OUTPUT SHAFT SPACER CODE F1
5307M	OUTPUT SHAFT D160 42MM CODES S1
5314M	OUTPUT FLANGE D160 FIXED BY 6-M12X70 SOCKET HD. CAP CODE F1
5316M	MOTOR ADAPTER D160/D180 FIXED BY 4-M16X40 SOCKET HD. CAP CODE D1
5317M	OUTPUT SHAFT D160 42MM CODE F1
5320M	METRIC MOTOR SEE MOTOR NAMEPLATE FOR DETAILS FIXED BY 4-M16X40 SOCKET HD. CAP
5322M	ROTOR HUB D160 42MM FIXED BY 1-M8X16 CUP POINT GRUB SCREW, 1-M8X16 CONE POINT GRUB SCREW CODE D1
5323M	ROTOR HUB D180 48MM FIXED BY 1-M8X16 CUP POINT GRUB SCREW, 1-M8X16 CONE POINT GRUB SCREW CODE D1
5325M	INPUT ASSY. METRIC CODE K1
5350M	KEYSTOCK METRIC D160 8X12X80 CODE S1
5001	CASING
5002	STATOR FLANGE FIXED BY 5-M10X50 SOCKET HD. CAP, 4-M16X40 HEX. HD. BOLTS
5003	STATOR BODY FIXED BY 5-M10X50 SOCKET HD. CAP
5004	TACH GENERATOR HOUSING FIXED BY 6-M6X20 SOCKET HD. CAP
5016	GRILLES SMALL INLET FIXED BY 4-M5X8 PAN HD. SLOTTED
5017	GRILLES LARGE OUTLET FIXED BY 6-M5X8 PAN HD. SLOTTED
5018	INNER SEAL PLATE FRONT BEARING
5019	OUTER SEAL PLATE FRONT BEARING
5020	REAR BEARING SPACER
5022	BEARING FRONT NU311
5023	BEARING REAR 6212Z FIXED BY PART NO. 5024
5024	REAR BEARING CIRCLIP
5028	OIL SEAL 50X65X8
5030	COIL RETAINING RING
5034	EYEBOLT M16
5065	HP COIL FOR 4/11KW, 4/15KW, 2/18.5KW FIXED BY PART NO. 5030 CODES H10, H20, N1, N2
5066	HP COIL FOR 4/22KW FIXED BY PART NO. 5030 CODES H10, H20, N1, N2
5069	HP COIL FOR 4/18.5KW, 2/30KW, 2/37KW FIXED BY PART NO. 5030 CODES H10, H20, N1, N2
5079	POLEWHEEL STD. FIXED BY 1-M12X50 SOCKET HD. CAP, 1-M12 FLAT WASHER, 4-M8X36 SLOTTED SPRING PINS
5087	POLEWHEEL RED. FIXED BY 1-M12X50 SOCK. HD. CAP, 1-M12 FLAT WASHER, 4-M8X35 SLOT. SPRING PINS
5097	POLEWH. RED. WITH AXIAL BLADES FIXED AS P/N 5079 OR P/N 5087
5073	TORQUE TUBE/ROTOR ASSY. 4 POLE FIXED BY 6-M8X40 SOCKET HD. CAP
5173	TORQUE TUBE / ROTOR ASSY 4-POLE FIXED BY 6-M8X40 SOCKET HD CAP (NICKEL PLATED)
5089	TORQUE TUBE/ROTOR ASSY. 2 POLE FIXED BY 6-M8X40 SOCKET HD. CAP
5189	TORQUE TUBE/ROTOR ASSY. 2 POLE FIXED BY 6-M8X40 SOCKET HD. CAP (NICKEL PLATED)
5084	TORQUE TUBE/ ROTOR ASSY. FAN TUBE FIXED BY 6-M8 SOCKET DH. CAP
5184	TORQUE TUBE/ ROTOR ASSY. FAN TUBE FIXED BY 6-M8 SOCKET DH. CAP (NICKEL PLATED)
5302	TOTALLY ENCLOSED COVERS LEFT HAND FIXED BY 5-M5X16 SOCKET HD. CAP CODES T1, T2
5303	TOTALLY ENCLOSED COVERS RIGHT HAND FIXED BY 5-M5X16 SOCKET HD. CAP CODES T1, T2
5319	PLASTIC PLUGS 6 - # 8 CODES T1, H10, N1
5500	TACH ARMATURE FIXED BY 2-M5X8 CONE POINT GRUB SCREWS
5501	HOSEPROOF COVERS SMALL INLET FIXED BY 4-M5X60 STUD CODES N1, N2
5502	BAFFLES FOR PART NO. 5501 CODES N1, N2
5503	HOSEPROOF COVERS LARGE OUTLET FIXED BY 4-M5X60 STUD CODES N1, N2
5504	BAFFLES FOR PART NO. 5503 CODES N1, N2
9005	TERMINAL BOX FIXED BY 4-M5X60 STUD, 4-M5 RUBBER WASHERS, 4-M5 FLAT WASHERS, 4-M5 LOCKNUT
9006	TERMINAL BOX LID
9008	TACH GENERATOR ASSY. FIXED BY 4-M4X14 SOCKET HD. CAP, 4-M4 FLAT WASHERS
9014	TERMINAL BOX GASKET
9035	PLASTIC PLUGS 2 - # 12 CODES T1, T2
9039	NAMEPLATE FIXED BY 4-6X1/4 TAPPING SCREWS
9305	TERMINAL BLOCK 4 WAY FIXED BY 1-M5X12 SOCKET HD. CAP
9306	TERMINAL BLOCK 6 WAY FIXED BY 1-M5X12 SOCKET HD. CAP CODES B? Y?

TORSPEC MODEL 180TCD-M PARTS DIAGRAM

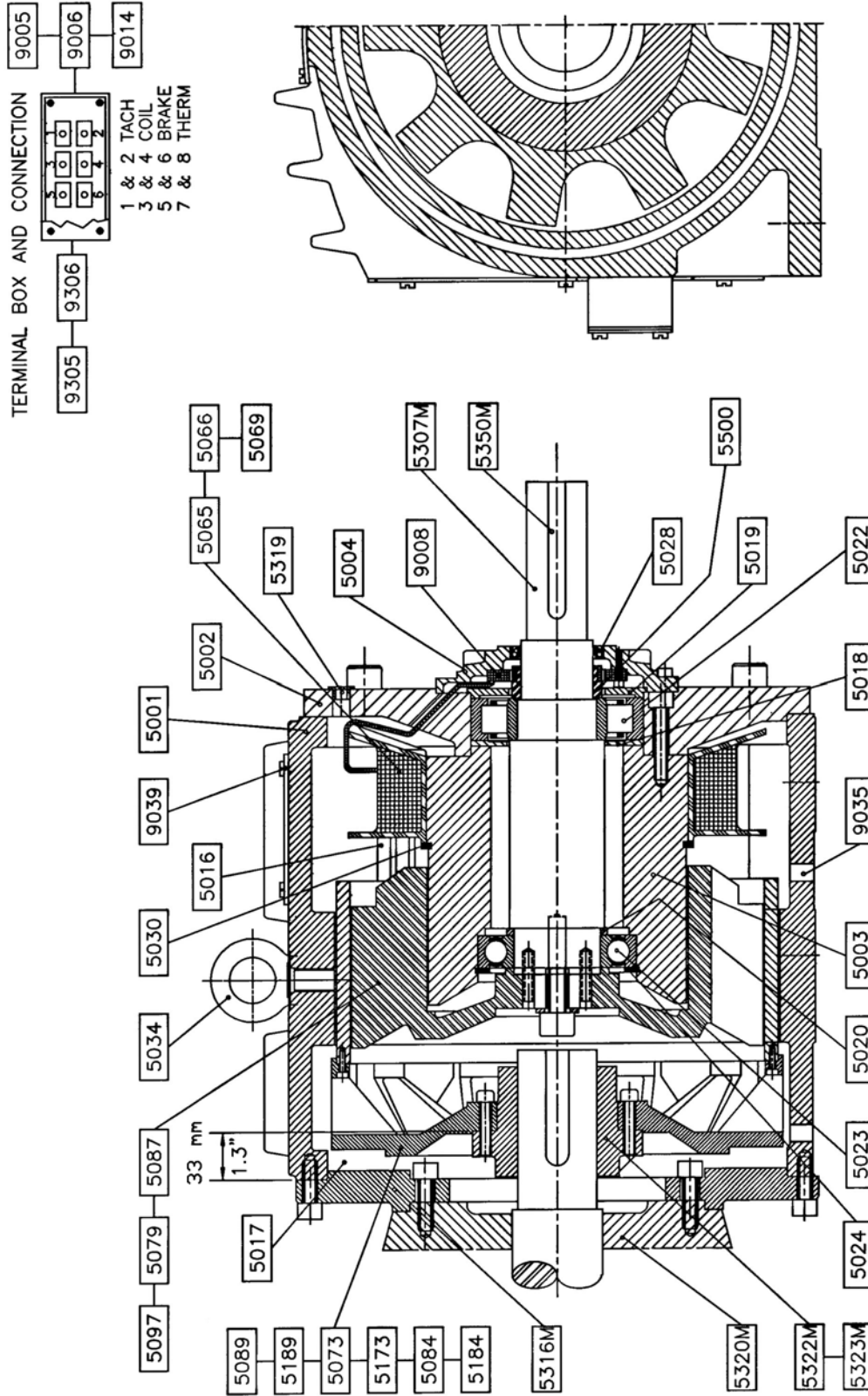

	180TCD CLUTCH UNIT – METRIC	Rev# 1
	BASIC UNIT – FOOT MOUNTED	
	Oct./ 2001	

DRIVE FEET MOUNTING PROCEDURES

F1: Push slotted Shims under the Coupling lowest mounting feet and moderately tighten the Bolts

F2: Align the unit. Insert Feeler Gauges under the remaining feet during the alignment process to level the unit.

F3: Replace feeler gauges with equal thickness of slotted Shims. Use a few thick shims rather than a large number of thin shims.

F4: Alternately tighten Bolts.

F5: Recheck alignment and change shims as required.

F6: Push slotted Shims under AC Motor mounting feet and moderately tighten the bolts.

Note:

-The decision to mount (bolt) the Motor feet should be based on the application dynamics. (I.e. vibration/support). It is not always necessary to mount the motor feet and is specifically motor size related.

-When Drives are purchased on base, base must also be leveled and secured.

Warning:

Failure to properly mount and level drive unit may result in distortion to the drive housing, torque tube, mechanical failure, misalignment, and premature bearing wear.