

TORSPEC™ VARIABLE SPEED DRIVE

INSTALLATION AND MAINTENANCE INSTRUCTIONS

TORSPEC MODEL 225TCD-NEMA

TORSPEC VARIABLE SPEED DRIVES

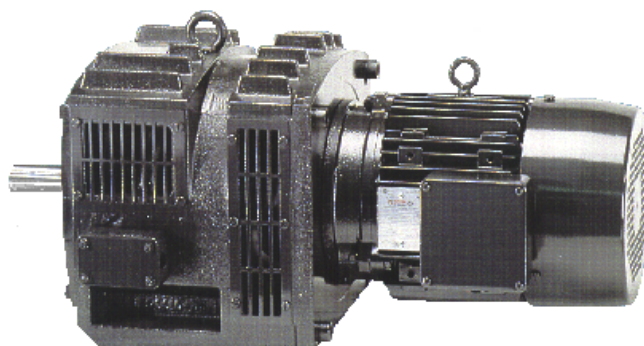

SIMPLE - RUGGED - RELIABLE

WARNING

Disconnect all incoming power before working on this equipment.

Follow power lockout procedures.

Use extreme caution around electrical equipment.

Do not touch the circuit board while power is applied.

TORSPEC™

International Inc.
40 Claireville Drive, Etobicoke
(Toronto), Ontario, Canada M9W 5T9
Phone: (416) 213-1026
Fax: (416) 213-0821
E-mail: Sales@torspec.com

International (USA) Inc.
13507-C East Boundary Road
Midlothian (Richmond), VA U.S.A. 23112
Phone: (804) 744-5521
Fax: (804) 744-9131
E-mail: Torspecusa@aol.com

Web-Site: www.torspec.com

Manufacturers & Suppliers of World Class Quality Variable Speed Drives & Controls

TORSPEC MODEL 225TCD-NEMA DISMANTLING INSTRUCTIONS

CAUTION - BE SURE TO DISCONNECT POWER AND FOLLOW LOCK--OUT PROCEDURES AS SPECIFIED BY LAW **BEFORE** OPENING ANY TERMINAL BOXES OR TOUCHING ANY WIRING.

D1: Open terminal box and disconnect drive wires. **EXTREME CAUTION** should be exercised with the small wires going to the tach generator, as they can be easily broken.

Hint: (Look for broken wires, or poor connections.)

D2: Remove four bolts holding output assembly to main casing. Remove output assembly while feeding wires through the hole, once the wires are free, the output assembly can be completely removed.

Hint: (Look for physical damage, remove any build up of foreign material on polewheel which could cause binding. Binding will cause the drive to run at full speed when the motor is started even if the clutch is turned off.)

D3: The polewheel is removed by removing the bolt in the center that is attaching it to the output shaft and inserting a larger 24mm bolt to push it off.

D4: The coil is held in place by a circlip at the back and silicone sealant at the front. After removing the circlip it is necessary to use a thin blade to break the sealant between the coil form and the front of the output assembly. **Care must be used, the former is breakable.**

Hint: (Look for physical damage, signs of overheating, coil should be 20 to 40 ohms depending on size. Low resistance will cause the control fuses to blow, too high will result in poor performance.)

D5: To separate the coil and tach wires cut the waxed string and **carefully** slide the rubber tube off. If the tach is being replaced, a string or small wire tied to the old tach wires before removing can be used to assist in pulling in the new wires.

Hint: (Look for broken wires, tach should be 220 ohms, a bad tach will cause the drive to run at full speed when the controller is energized.)

D6: Remove the tach cover plate and tach stator. The tach armature is potted in place in to the shaft and cannot be removed.

Hint: (Look for broken magnetic strip, this will give the same symptoms as a bad tach.)

D7: Remove rear bearing clamp plate and draw the shaft out of the assembly from the polewheel side by pressing on the tach side of the shaft. Remove the front bearing inner race and bearing spacer. Remove the front bearing outer race.

D8: The two rear ball bearings can now be pressed off.

D9: Remove the motor adapter flange from the main casing. Remove the 6 cap head screws holding the torque tube assembly to the hub on the motor shaft. Two grub screws hold the hub on the shaft, be sure to remove these grub screws completely as one is counter sunk into the shaft.

Hint: (Look for pitting and/or lifting of the copper lining on the torque tube, this is what transmits the power and damage here will cause the drive to be short of power)

TORSPEC MODEL 225TCD-NEMA ASSEMBLY INSTRUCTIONS

USE A THREAD LOCKING COMPOUND ON ALL BOLTS

- A1: If the motor is being replaced it will be necessary to dimple the shaft in the same location as the original motor. ***This location is critical for proper alignment.*** Use an anti-seize compound on the shaft. Mount the torque tube hub with one of the grub screws in the dimple
- A2: Mount the motor adapter flange onto the motor flange with the flat on the bottom. Mount the torque tube on the hub. Bolt the motor assembly onto the main casing.
- A3: Mount the pre-greased outer roller bearing into the output assembly. Place the front bearing spacer and press the inner race onto the shaft. Place the grease shield and press the pre-greased matched pair, ball bearings onto the back of the shaft, be sure to press on the inner race only and ensure correct faces match. Insert the shaft assembly into the output assembly from the polewheel side by pressing on the outer rear bearing. Replace the rear bearing plate.
- A4: Feed the tach wires through the hole in the output assembly and slide the tach stator plate over the shaft and bolt to the output assembly. ***Be sure not to pinch the tach wires.***
- A5: Apply silicone rubber to the front of the main coil and push the coil onto the output assembly. Install the coil circlip. Push the tach wires, then the coil wires into the rubber sleeving. Tie off with a piece of waxed string.
- A6: Bolt the polewheel onto the shaft ensuring the spring pins are in place and the polewheel completely seats.
- A7: Insert the output assembly into the casing while feeding the wires through the hole. Bolt into place on main casing.

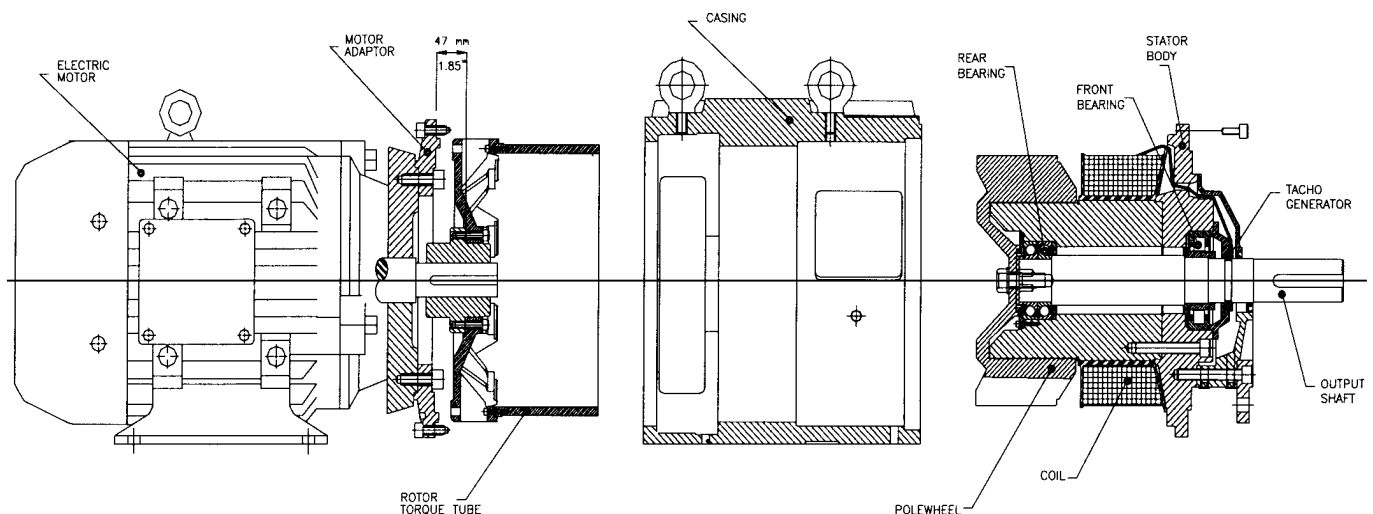

TORSPEC 225TCD-N PARTS LIST

PART NO.	DESCRIPTION
6007N	OUTPUT SHAFT NEMA 364T 2 3/8" CODE S2
6050N	KEYSTOCK NEMA 364T 5/8 SQ.X5.125" CODE S2
6106N	MOTOR ADAPTER 284/286TC FIXED BY 8-M12X50 SOCKET HD. CAP CODE D2
6107N	ROTOR HUB 284/286TC 1 7/8" FIXED BY 1-M10X16 CUP POINT GRUB SCREW, M10X16 CONE POINT GRUB SCREW CODE D2
6109N	MOTOR ADAPTER 324/326TC FIXED BY 8-M12X50 SOCKET HD. CAP CODE D2
6110N	MOTOR ADAPTER 364TC FIXED BY 8-M12X50 SOCKET HD. CAP CODE D2
6113N	ROTOR HUB 324/326TC 2 1/8" FIXED BY 1-M10X16 CUP POINT GRUB SCREW, 1-M10X16 CONE POINT GRUB SCREW CODE D2
6114N	ROTOR HUB 364TC 2 3/8" FIXED BY 1-M10X16 CUP POINT GRUB SCREW, 1-M10X16 CONE POINT GRUB SCREW CODE D2
6116N	OUTPUT FLANGE 364TC
6120N	NEMA MOTOR SEE MOTOR NAMEPLATE FOR DETAILS FIXED BY 284/286TC - 4-1/2" X 1 1/2" SOCKET HD. CAPII 324/364TC=4-5/8" X 1 3/4" SOCKET HD. CAPII 364TC = 8-5/8"X2" SOCKET HD. CAP
6319N	PLASTIC PLUGS 4- #21 CODE D2
6324N	INPUT ASSY. NEMA CODE K2
6001	CASING
6002	STATOR FLANGE FIXED BY 4-M16X50 HEX HD.BOLT
6003	STATOR BODY FIXED BY 6-M16X90 SOCKET HD. CAP
6004	OUTPUT COVER FIXED BY 4-M8X20 SOCKET HD. CAP
6005	TERMINAL BOX FIXED BY 4-M5X12 SOCKET HD. CAP
6006	TERMINAL BOX LID FIXED BY 4-M5X12 PHILLIPS PAN HD.
6009	TACH MOUNTING PLATE FIXED BY 8-M5X16 SOCKET HD. CAP
6014	TERMINAL BOX LID GASKET
6015	TERMINAL BOX GASKET
6016	GRILLES SMALL INLET FIXED BY 4-M6X10 SLOTTED PAN HD.
6017	GRILLES LARGE OUTLET FIXED BY 8-M6X10 SLOTTED PAN HD.
6018	INNER FRONT BEARING SPACER
6019	OUTER FRONT BEARING COLLAR FIXED BY 3-M5X8 CUP POINT GRUB SCREWS
6020	INNER REAR BEARING SPACER
6022	BEARING FRONT NU313B
6023	BEARINGS REAR 7212BECGP-SKF SUITABLE FOR USE AS A PAIR
6024	BEARING CLAMP PLATE FIXED BY 8-M5X16 SOCKET HD. CAP
6028	OIL SEAL 85X62X10
6030	COIL RETAINING RING
6034	EYEBOLTS 2-M16
6035	PLASTIC PLUGS 2- #13 CODES T1, T2
6038	OIL SEAL 90X62X10 CODE F?
6065	HP COIL FOR 4/30HP FIXED BY PART NO. 6030 CODES H10, H20, N1, N2
6066	HP COIL FOR 4/50HP, 4/60HP FIXED BY PART NO. 6030 CODES H10, H20, N1, N2
6069	HP COIL FOR 4/40HP FIXED BY PART NO 6030 CODES H10, H20, N1, N2
6073	TORQUE TUBE/ROTOR ASSY. FIXED BY 6-M12X50 SOCKET HD. CAP
6173	TORQUE TUBE/ROTOR ASSY- 4 POLE., FIXED BY 6-M12X50 SOCKET HD. CAP (NICKEL PLATED)
6079	POLEWHEEL STD. FICED BY 1-M20X50 SOCKET HD. CAP, 1-M20 FLAT WASHER, 4-M10X30 SLOTTED SPRING PINS
6087	POLEWHEEL REDUCED FIXED BY 1-M20X50 SOCKET HD. CAP, 1-M20 FLAT WASHER, 4-M10X36 SLOTTED SPRING PINS CODE R
6097K	POLEWHEEL RED. C/W AXIAL BLADES FIXED AS P/N 6087
6084	TORQUE TUBE/ROTOR ASSY- FAN DRIVE TUBE, FIXED BY 6-M12X50 SOCKET HD. CAP
6184	TORQUE TUBE/ROTOR ASSY- FAN DRIVE TUBE, FIXED BY 6-M12X50 SOCKET HD. CAP (NICKEL PLATED)
6300	FLANGE SPACER CODES F?
6302	TOTALLY ENCLOSED COVERS LEFT HAND FIXED BY 7-M6X16 SOCKET HD. CAP CODES T1, T2
6303	TOTALLY ENCLOSED COVERS RIGHT HAND FIXED BY 7-M6X16 SOCKET HD. CAP CODES T1, T2
6501	HOSEPROOF COVERS SMALL INLET FIXED BY 4-M6X16 SOCKET HD. CAP CODES N1, N2
6502	HOSEPROOF COVERS LARGE OUTLET FIXED BY 4-M6X16 SOCKET HD. CAP CODES N1, N2
9008	TACH GENERATOR ASSY. FIXED BY 4-M4X16 SOCKET HD. CAP, 4-M4 FLAT WASHER
9035	PLASTIC PLUG 2- #12 CODE F
9039	NAMEPLATE FIXED BY 4-M6X3.5MM TAPPING SCREWS
9305	TERMINAL BLOCK 4 WAY FIXED BY 1-M4X12 SOCKET HD. CAP
9306	TERMINAL BLOCK 6 WAY FIXED BY 1-M4X12 SOCKET HD. CAP CODES B? Y?
9501	ARMATURE STRIP EPOXIED TO SHAFT

TORSPEC MODEL 225TCD-N PARTS DIAGRAM

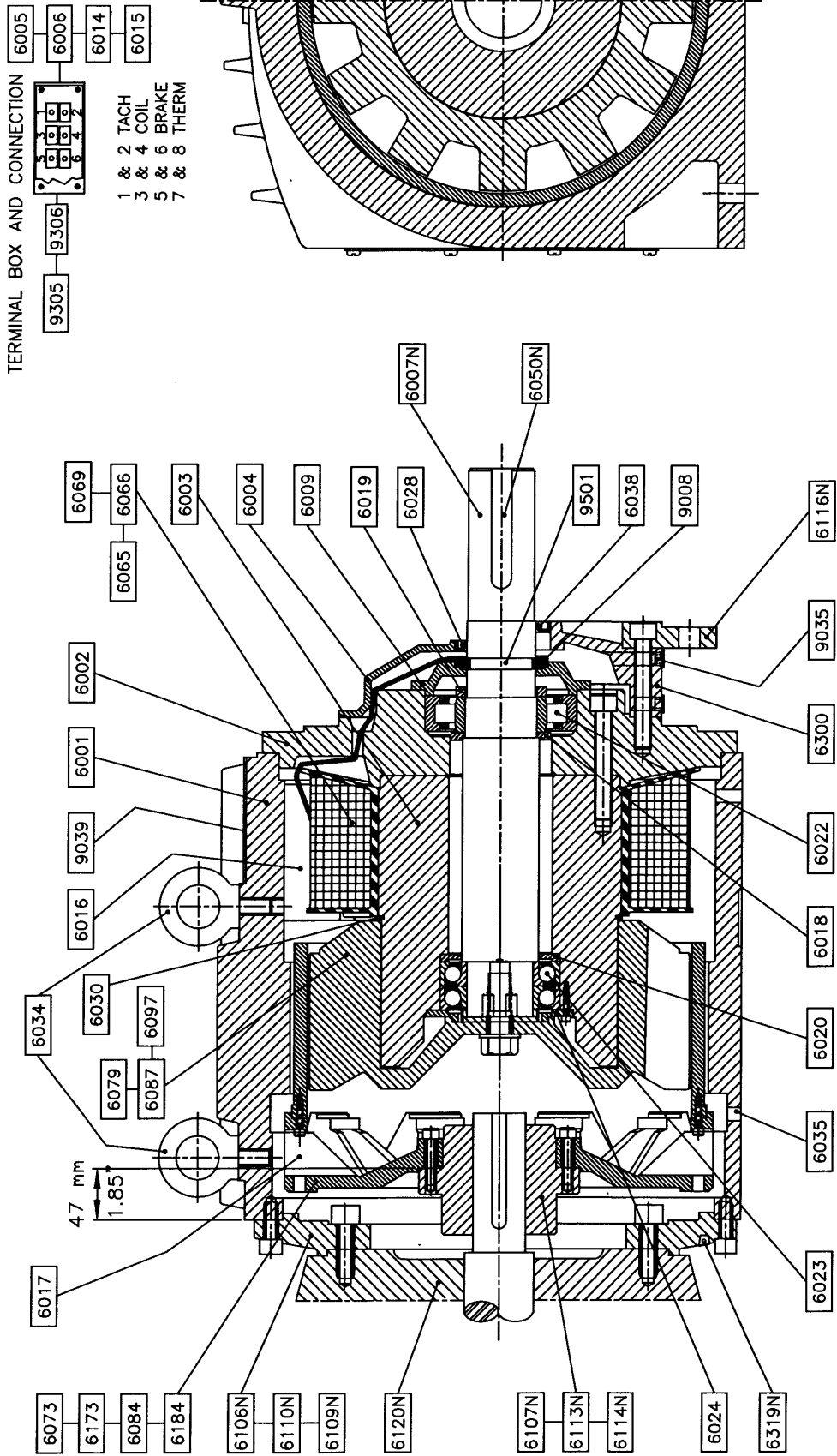

TORSPEC™ INTERNATIONAL INC.	225TCD CLUTCH UNIT - N.E.M.A.
	BASIC UNIT - FOOT MOUNTED
File: Instr_225/225assyN	March/02 R# 1

NOTES:
NOT SHOWN:
6314N INPUT ASSEMBLY
6302,03 TOTALLY ENCLOSED COVERS
6501, 02, 03, 04 DEBRIS COVERS

DRIVE FEET MOUNTING PROCEDURE

- F1: Push slotted Shims under the Coupling lowest mounting feet and moderately tighten the Bolts
- F2: Align the unit. Insert Feeler Gauges under the remaining feet during the alignment process to level the unit.
- F3: Replace feeler gauges with equal thickness of slotted Shims. Use a few thick shims rather than a large number of thin shims.
- F4: Alternately tighten Bolts.
- F5: Recheck alignment and change shims as required.
- F6: Push slotted Shims under AC Motor mounting feet and moderately tighten the bolts.

Note:

-The decision to mount (bolt) the Motor feet should be based on the application dynamics. (I.e. vibration/support). It is not always necessary to mount the motor feet and is specifically motor size related.

-When Drives are purchased on base, base must also be leveled and secured.

Warning:

Failure to properly mount and level drive unit may result in distortion to the drive housing, torque tube, mechanical failure, misalignment, and premature bearing wear.