

TORSPEC™ VARIABLE SPEED DRIVE



INSTALLATION AND SETTING UP MANUAL 3035TCP MULTIDRIVE REFERENCE POWER SUPPLY CONTROLLER

WARNING

*Disconnect all incoming power before working on this equipment.
Follow power lockout procedures.
Use extreme caution around electrical equipment.
Do not touch the circuit board while power is applied.*

TORSPEC

International Inc.
40 Claireville Drive, Etobicoke
(Toronto), Ontario, Canada M9W 5T9
Phone: (416) 213-1026
Fax: (416) 213-0821

International (USA) Inc.
13507-C East Boundary Road
Midlothian (Richmond), VA U.S.A. 23112
Phone: (804) 744-5521
Fax: (804) 744-9131

Web-Site: www.torspec.com

Manufacturers & Suppliers of World Class Quality Variable Speed Drives & Controls

TABLE OF CONTENTS

SYSTEM DESCRIPTION	3
CONSTRUCTION	3
CONTROLLER PHYSICAL DETAILS	3
SPECIFICATIONS	3
Abbreviations	3
WARNINGS	4
MASTER CONTROL	4
OUTPUTS	4
SETTING-UP INSTRUCTIONS FOR MULTIDRIVE REFERENCE POWER SUPPLY TYPE 3035TCP	5
3035TCP JUMPER SETTINGS.....	5
3035TCP CONTROLLER SCHEMATIC.....	6
3035TCP CONTROLLER MULTI-REFERENCE CONNECTION DIAGRAM	7
3035TCP CONTROLLER TOP SIDE SILK SCREEN.....	8

3035TCP MULTI-REFERENCED CONTROLLER

SYSTEM DESCRIPTION

The purpose of this unit is to enable a number of TORSPEC DRIVES to be controlled simultaneously with a single potentiometer. The unit will handle up to 12 drives.

CONSTRUCTION

All of the components are mounted on a double-sided epoxy glass printed circuit card, each component identified by a component code. The board is constructed for high reliability and serviceability. Termination is through a quick connect terminal strip with captive screws and retractable wire pressure plates.

CONTROLLER PHYSICAL DETAILS

Size 9.65" long x 5.24" high x 1.52" deep

Permissible temperature is 1-160°F local ambient around the controller providing the 160°F local ambient is equivalent to 122°F outside ambient when the controller is mounted in a small NEMA 12 enclosure.

SPECIFICATIONS

Supply Voltage:	110 - 120VAC, 220 - 240VAC ± 6%
Supply Frequency:	50 to 60 HZ

Maximum Nominal Output:	12 VDC
Maximum Current:	250mA

Abbreviations

ADC = Amps direct current	AAC = Amps alternating current
HZ = Hertz	MADC = Milli-amperes direct current
VAC = Volts alternating current	VDC = Volts direct current

WARNINGS

1. Provision must be made, at an external point, to isolate the supply voltage from the drive controller and motor.
2. Be sure the supply voltage, frequency and current are compatible.
3. The enclosure that the controller is to be fitted into must be grounded.
4. **The supply to the controller must be interlocked with the motor starter in such a way as to prevent the control board from being powered up if the motor is not operating.**
5. Please contact our service department if you experience any difficulties that are not covered in this manual.

MASTER CONTROL

This is a 1K potentiometer and it is connected with the top contact to terminal 6, the wiper contact to terminal 8, and the bottom contact to terminal 7. If the connecting cable is longer than 1 foot, then it should be shielded to prevent stray pick-up. Clockwise rotation will increase speed.

OUTPUTS

The 0 to 12 Volt output is connected to the (TORSPEC) controllers via shielded leads with the high side (+) going to terminal A9, and the low side (-) and the shield going to terminal A10. The pre-set controls on each controller can be used to independently trim max. and min. speed, torque; acceleration etc., as required. External trim pots may be added if required. Refer to drawing for connections.

SETTING-UP INSTRUCTIONS FOR MULTIDRIVE REFERENCE POWER SUPPLY TYPE 3035TCP

NOTE:

REFER TO SYSTEM SETTING UP INSTRUCTIONS WHERE POSSIBLE.

ENSURE J1 IS SET FOR DESIRED INPUT VOLTAGE (120 VAC OR 230 VAC)

SEE BOTTOM OF THIS PAGE FOR PROPER JUMPER SETTINGS

1. Connect up as shown on circuit diagram. Since this controller is used with other equipment there is no particular interconnection diagram and typical connections only are shown.
2. Connect reference load to terminals 9 and 10. This controller is usually used to control several TORSPEC drives from one common potentiometer and therefore replaces individual reference supplies.
3. Apply power to 3035TCP controller only.
4. Set MASTER SPEED potentiometer to maximum and check there is approximately 12 volts at terminals 9 and 10. P1 can be adjusted if maximum voltage required is less (e.g. 10 VDC).
5. Set MASTER SPEED potentiometer to minimum and check there is zero volts at terminals 9 and 10.
6. Apply power to complete system.
7. The individual (TORSPEC) drive speeds can now be set by the MASTER SPEED potentiometers.

3035TCP JUMPER SETTINGS

120 VAC

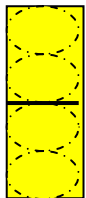

230 VAC

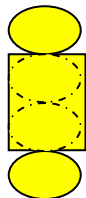

3035TCP CONTROLLER MULTI-REFERENCE CONNECTION DIAGRAM

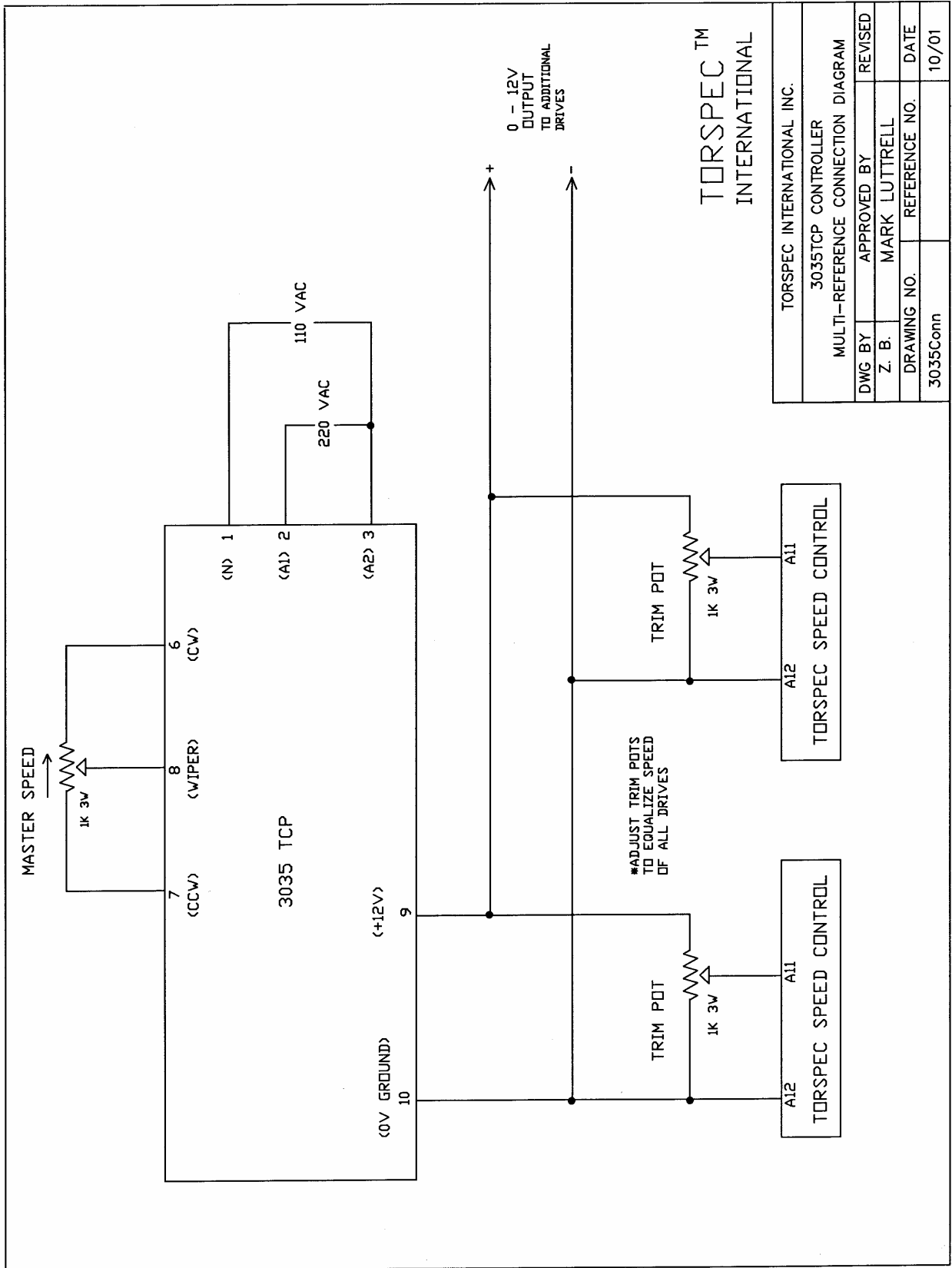

TORSPEC INTERNATIONAL INC.	
3035TCP CONTROLLER	
MULTI-REFERENCE CONNECTION DIAGRAM	
DWG BY	APPROVED BY
Z. B.	MARK LUTTRELL
DRAWING NO.	REFERENCE NO.
3035Conn	10/01

3035TCP CONTROLLER TOP SIDE SILK SCREEN

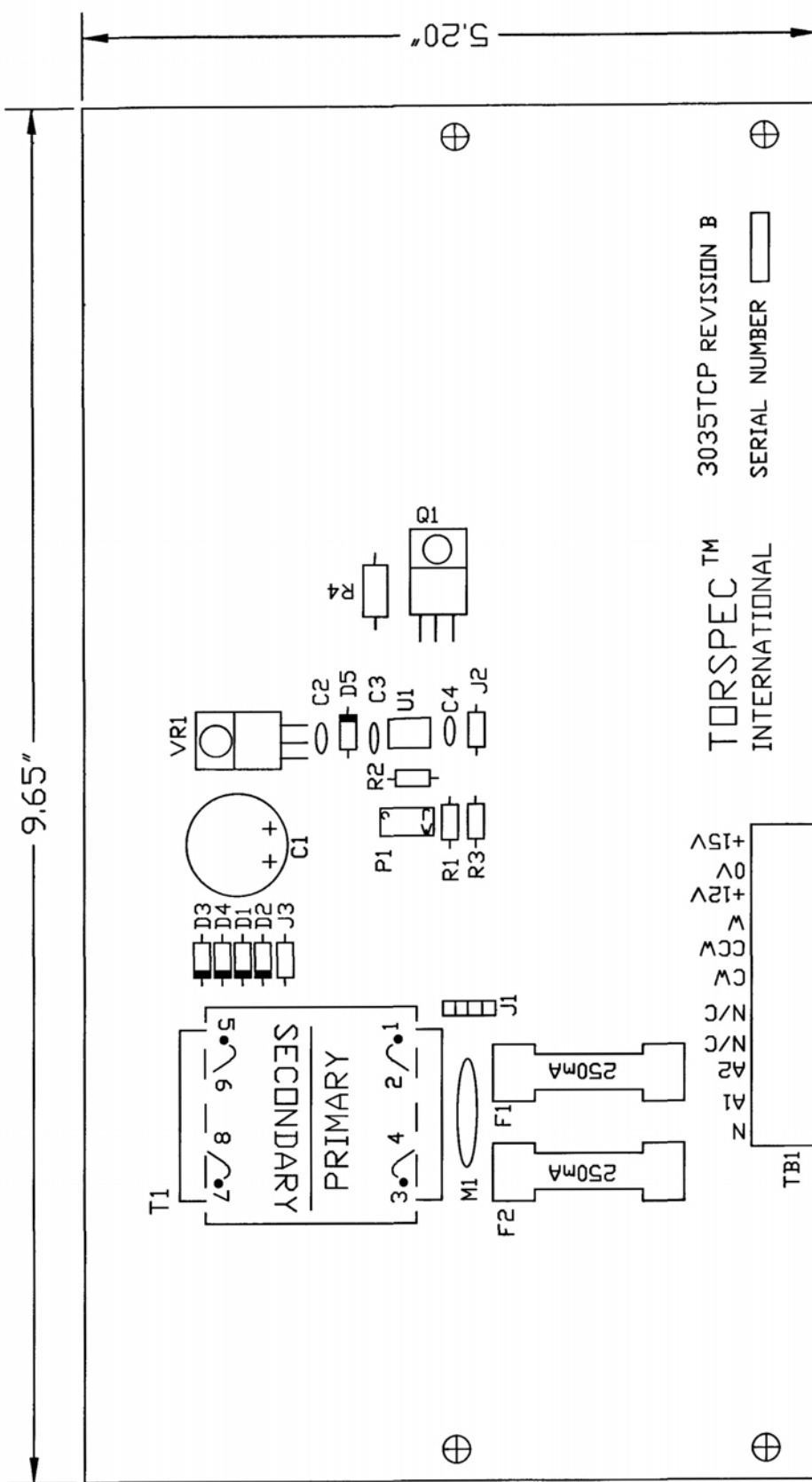

TORSPEC INTERNATIONAL INC.	
3035TCP CONTROLLER Top Side Silk Screen	
DWG BY	APPROVED BY
Z. B.	MARK LUTTRELL
DRAWING NO.	REFERENCE NO.
3035TCPmech.	09/01